

Antes de conectar la grifería a la distribución de agua, purgue muy bien la cañería a fin de eliminar partículas extrañas. /
Before connecting the faucet to the water supply, flush the tubing thoroughly to eliminate any residue

Juego de lavatorio / Widespread lavatory

FR217/J2.0

FR217/J2L.0

FR217/J2D.0

FR217/J2R.0

FR217/J2V.0

FR217/J2K.0

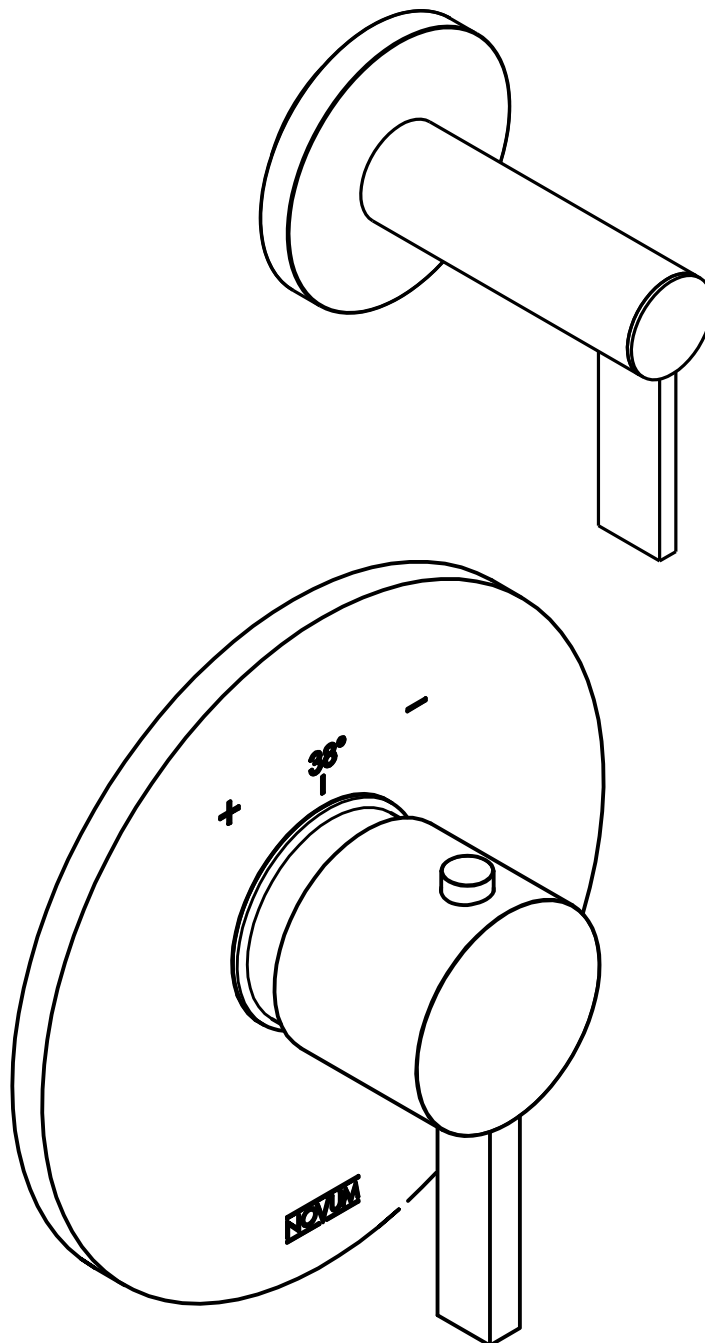

Herramientas requeridas para la instalación/Required installation tools

Provistas/Provided

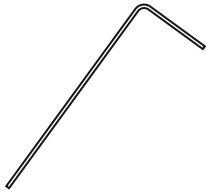

Llave Allen
Allen Wrench

No provistas/Not Provided

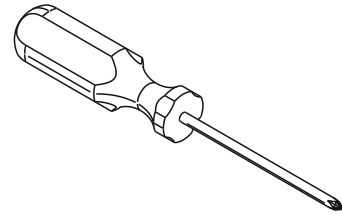

Destornillador Phillips
Phillips screwdriver

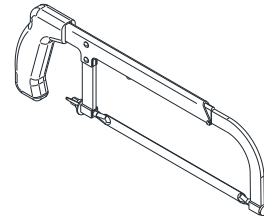

Sierra
Hacksaw.

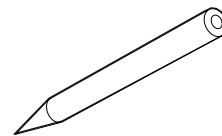

Marker
Marcador

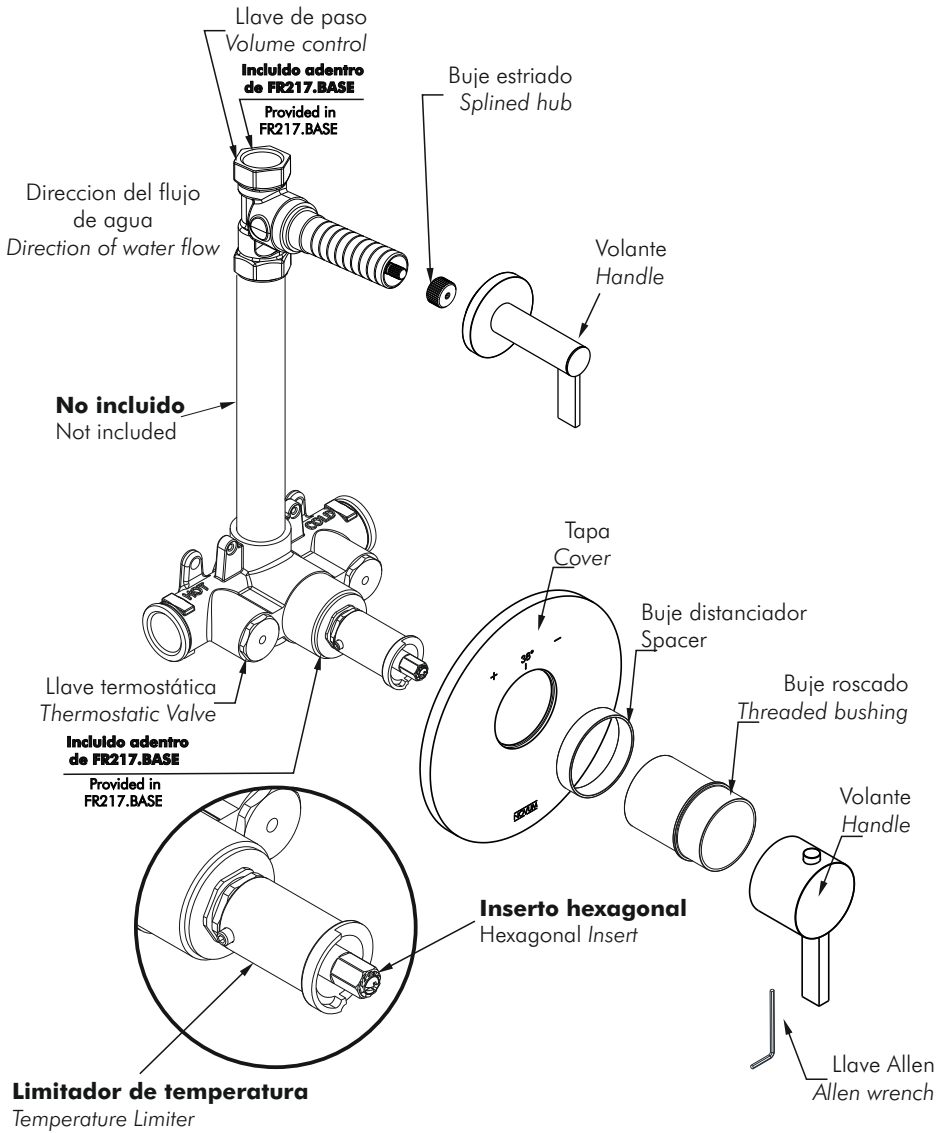

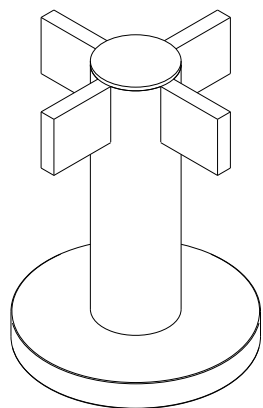

FR217/J2.0

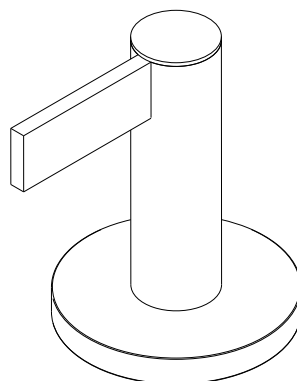

FR217/J2L.0

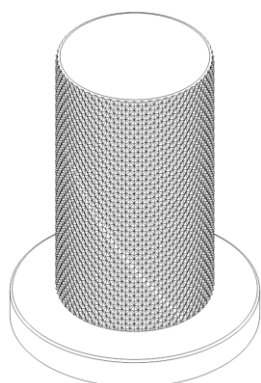

FR217/J2K.0

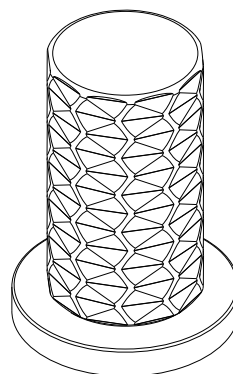

FR217/J2D.0

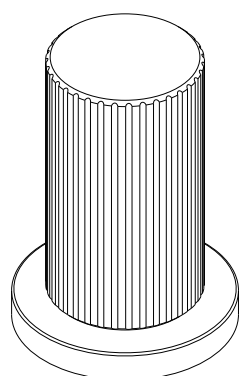

FR217/J2V.0

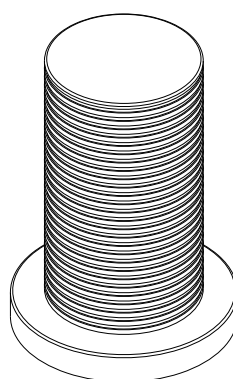

FR217/J2R.0

FR217/J2D.0
FR217/J2R.0
FR217/J2V.0
FR217/J2K.0

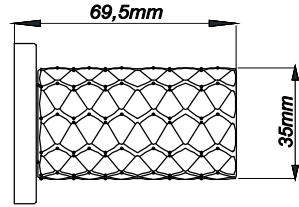
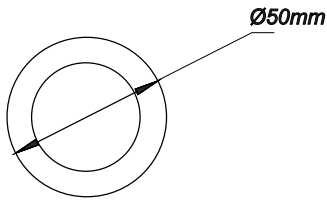

FR217/J2.0

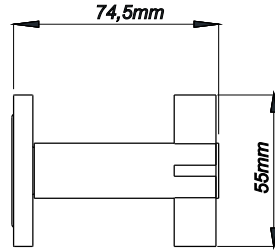
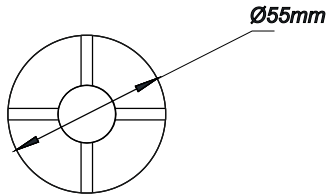

FR217/J2L.0

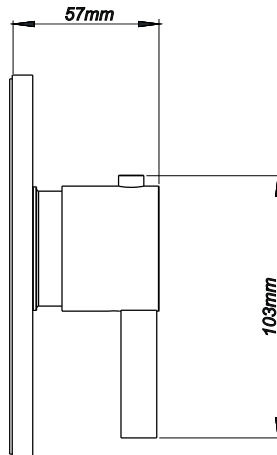
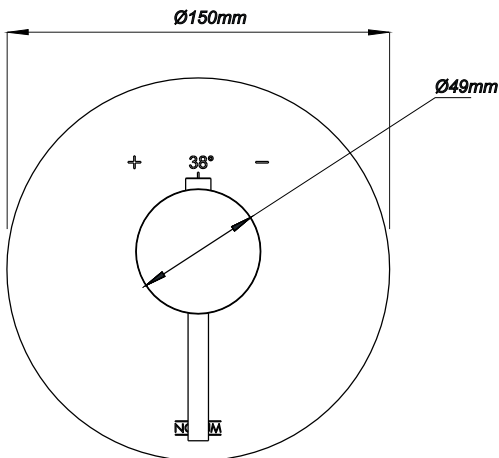
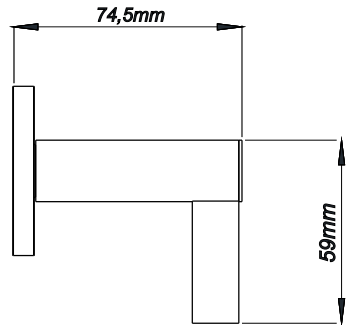
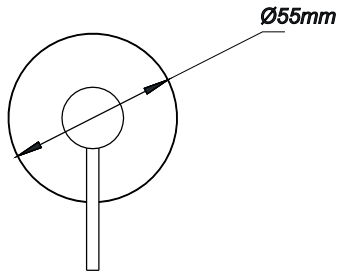

Remove la protección de instalación /
Remove installation covers.

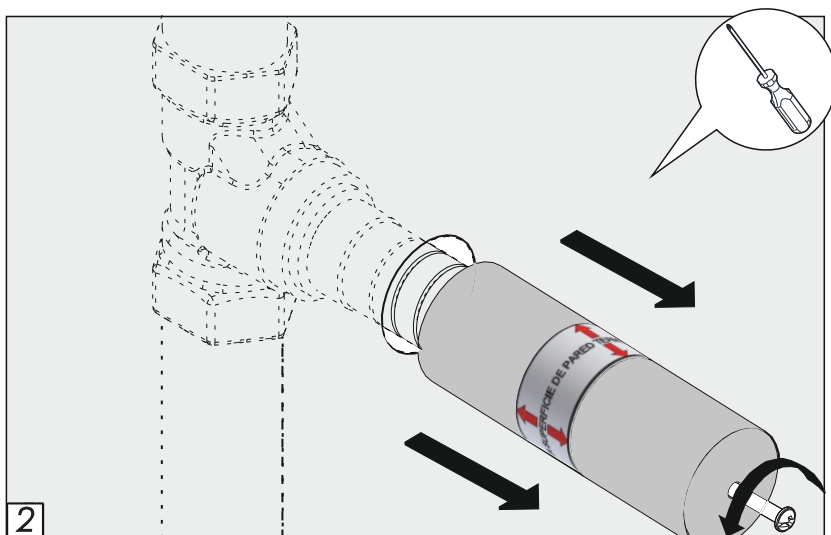
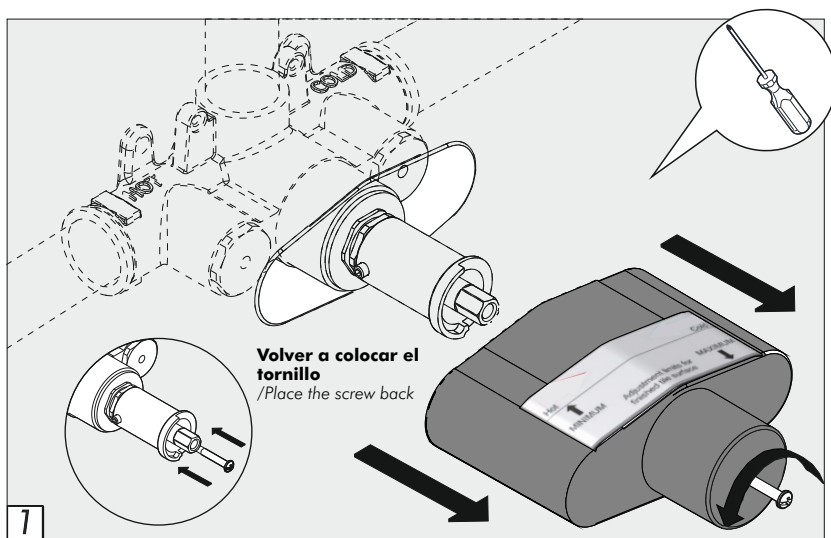

Asegurarse que la válvula este cerrada previo a regular /
 Make sure the valve is in its closed position before adjusting water temperature.

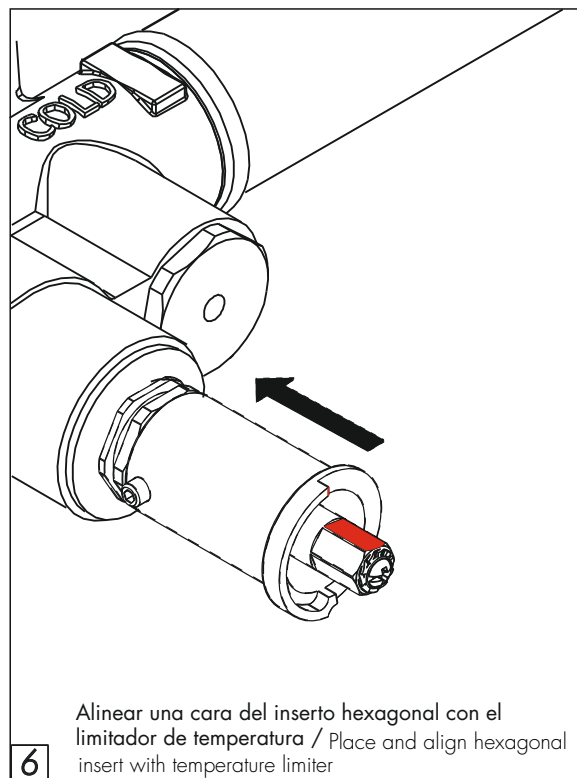
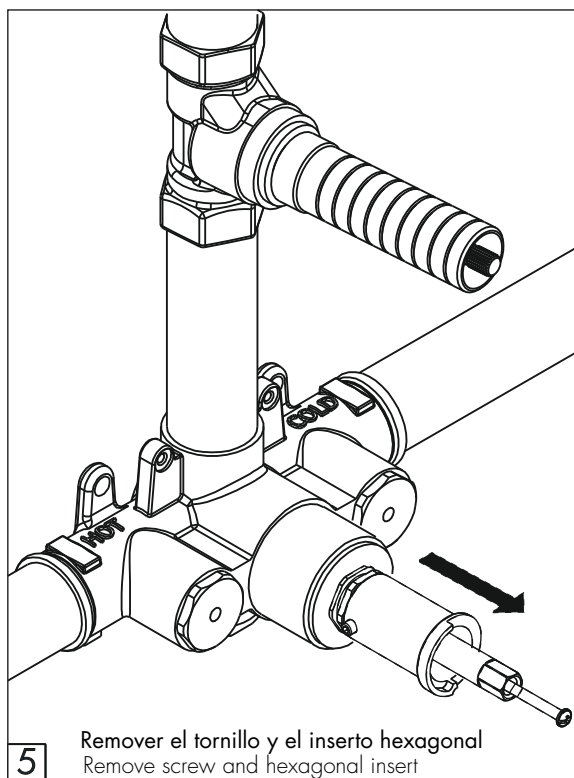
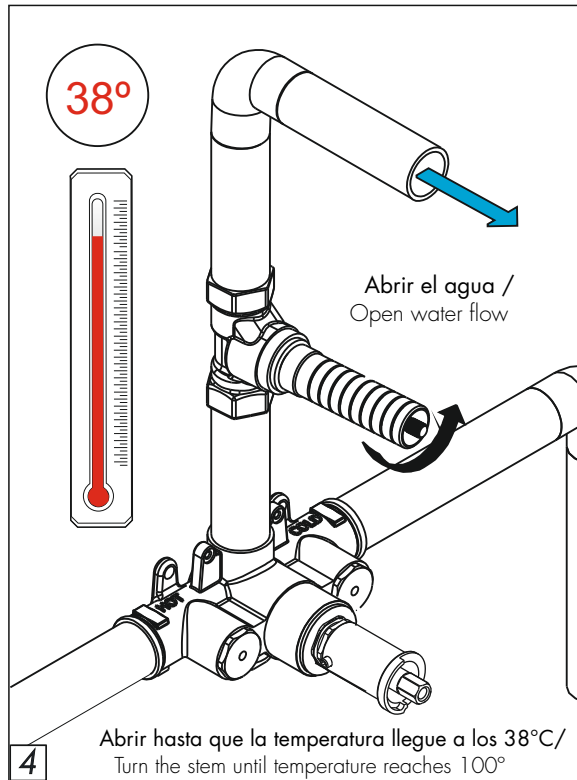
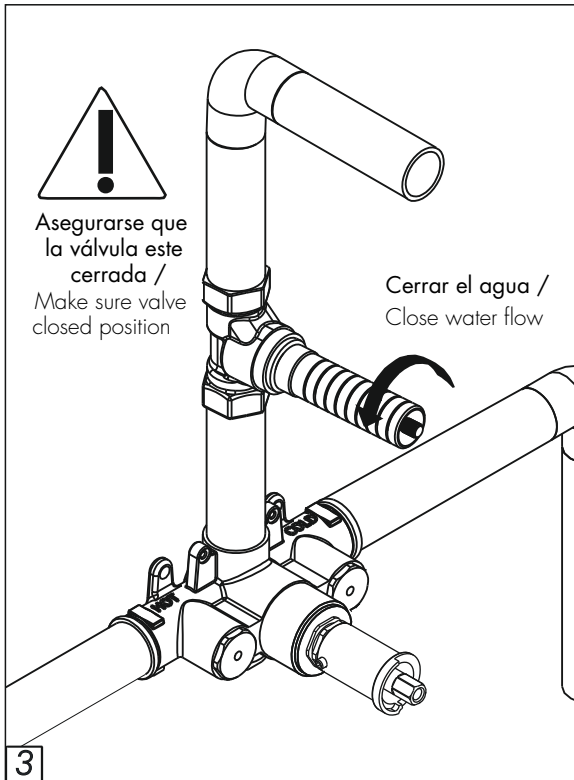

Instalación vista termostática.

Thermostatic trim installation.

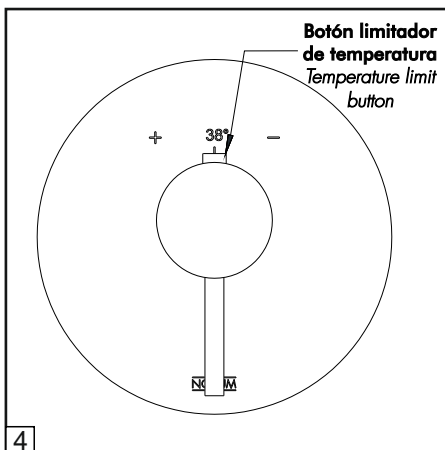
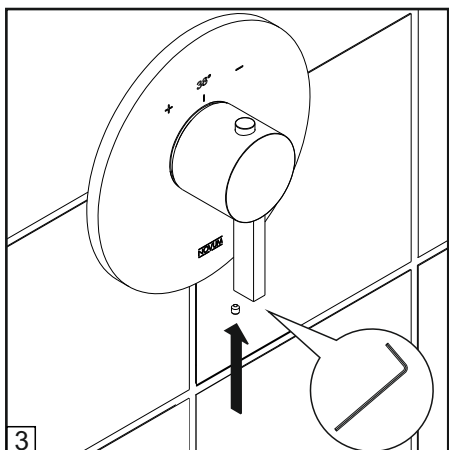
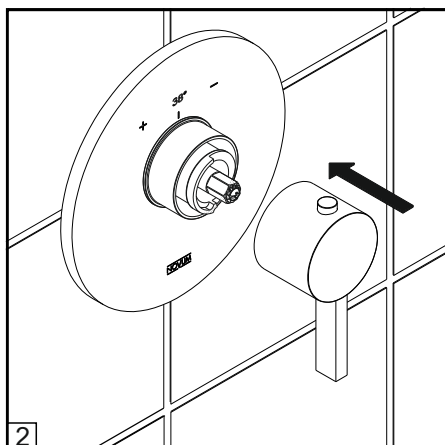
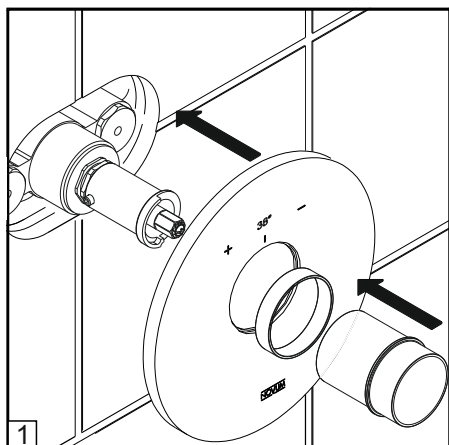

Instalación vista llave de paso.
Volume control trim installation.

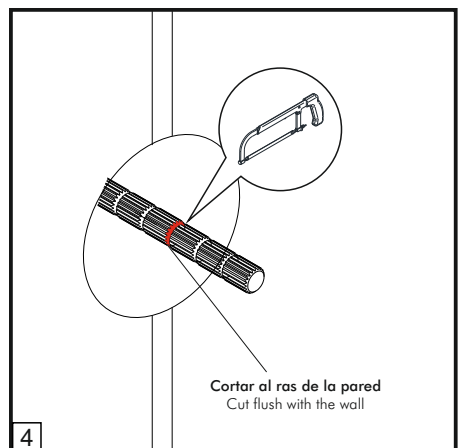
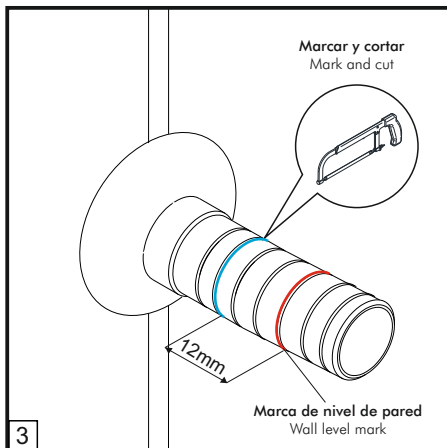
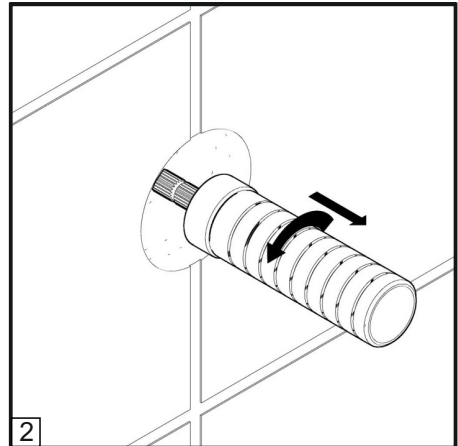
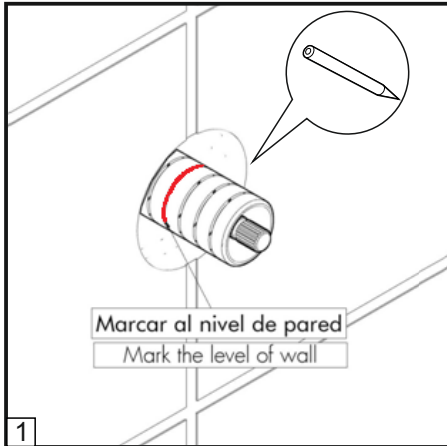

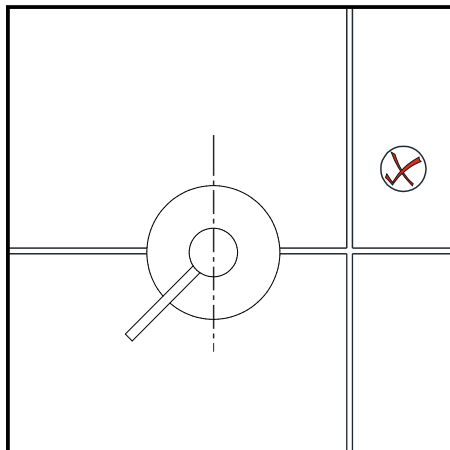
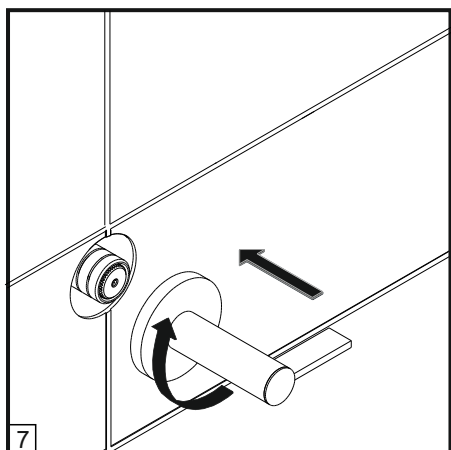
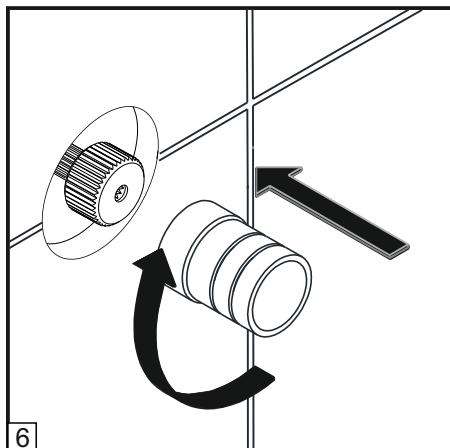
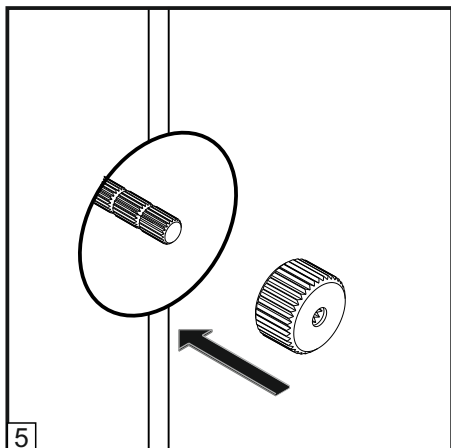

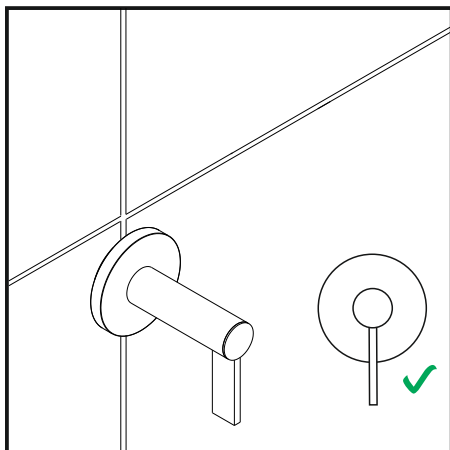
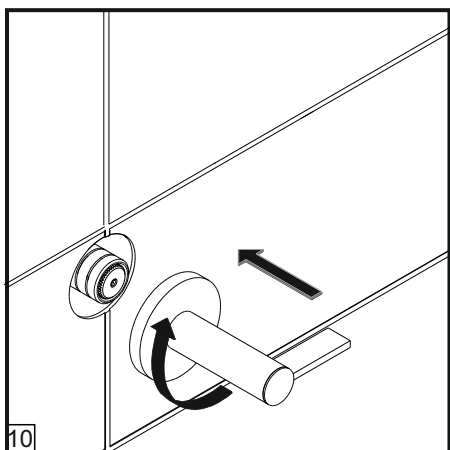
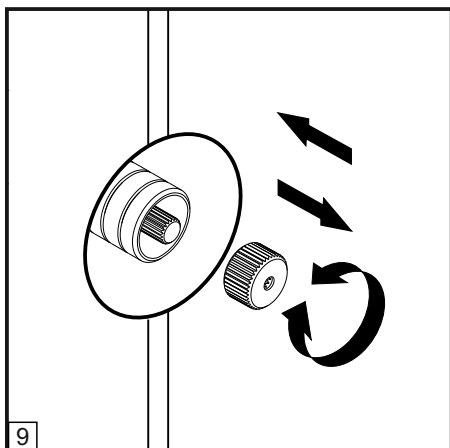
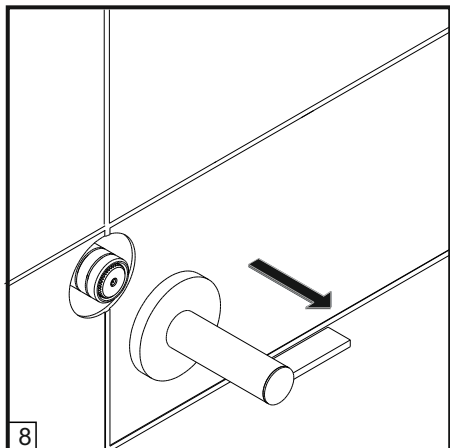

Instalación finalizada.
Finished installation.

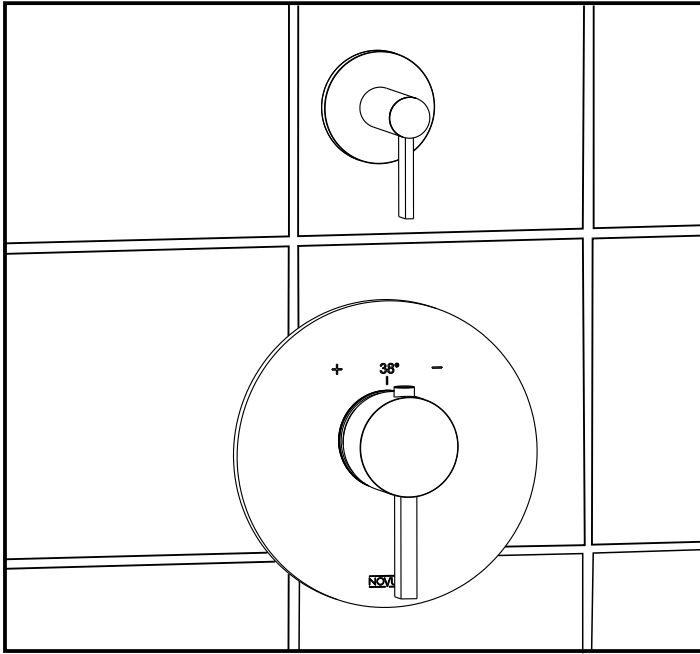

CERTIFICADO DE GARANTIA FV S.A.

LA GARANTIA DE FV AMPARA TODOS SUS PRODUCTOS CONTRA DEFECTOS DE FABRICACION.

LIMPIEZA Y MANTENIMIENTO DE LOS PRODUCTOS FV

LOS PRODUCTOS FV HAN SIDO FABRICADOS SEGUN TECNICAS DE AVANZADA Y CON MATERIALES DE PRIMERA CALIDAD, QUE LE ASEGURAN UNA PROLONGADA DURACION EN PERFECTAS CONDICIONES. A EFECTOS DE PRESERVAR ESTA CALIDAD LE SUGERIMOS TENER EN CUENTA ESTOS CONSEJOS:

NO USE LIMPIADORES ABRASIVOS, POLVOS DE LIMPIEZA, ESPONJAS METALICAS O DE FIBRA.
USE EN LO POSIBLE JABON NEUTRO O DETERGENTE DE USO DOMESTICO.
SEQUE CON PAÑO SUAVE.

AGRADECEMOS SU PREFERENCIA POR NUESTROS PRODUCTOS.

CONDICIONES DE VALIDEZ

SI A CRITERIO DEBIDAMENTE FUNDADO DE PERSONAL TECNICO DE FV SE COMPROBARA LA INTERVENCION DE MANO DE OBRA INEXPERTA EN LA COLOCACION, REPARACION Y/O MANTENIMIENTO DE LOS PRODUCTOS, ESTA GARANTIA PERDERA AUTOMATICAMENTE SU VALIDEZ. ASIMISMO SERA REQUISITO INEXCUSABLE PARA REALIZAR CUALQUIER RECLAMO DE GARANTIA LA PRESENTACION DE FACTURA DE COMPRA ORIGINAL.

1) EL FABRICANTE Y/O IMPORTADOR DE ESTE PRODUCTO ES FV S.A., UNA SOCIEDAD CONSTITUIDA Y REGULADA POR LAS LEYES DE LA REPUBLICA ARGENTINA, CON PLANTA EN VILLA ROSA (PROV. BS. AS.) Y SEDE SOCIAL EN RECONQUISTA 336 11º PISO, CAPITAL FEDERAL.

2) LA IDENTIFICACION DEL PRODUCTO Y LAS ESPECIFICACIONES TECNICAS NECESARIAS CONSTAN CONSIGNADAS EN CATALOGO, FOLLETERIA Y EN OFICINA TECNICA.

3) VER CONDICIONES DE USO, MANTENIMIENTO Y VALIDEZ DE LA GARANTIA EN EL TEXTO QUE PRECEDE.

4) LA REPARACION DE LOS PRODUCTOS FABRICADOS POR FV SOLO PODRA DELEGARSE EN PERSONAL CAPACITADO. EN CASO DE DUDA COMUNICARSE A LOS CENTROS DE ATENCION AL USUARIO.

5) PLAZO DE GARANTIA: 10 AÑOS.

Web: novum.fvsa.com

FV S.A.

Bernardo de Irigoyen 1053
B1604AFC - Florida
Pcia. de Buenos Aires - Argentina
novum.fvsa.com

Tel.: (011) 4730-5300

Fax: (011) 4730-5363

Centro de Atención al Usuario FV Responde para todo el País

Tel: 0810-555-5300

E-mail: fvresponde@fvsa.com

Sucursales:

Bahía Blanca
Pueyrredón 74 - B8000JOB Bahía Blanca
Tel.: (0291) 456-1999

Córdoba
Urquiza 2265 - X5001FTK Córdoba
Tel.: (0351) 471-8863

Mendoza
Maipú 235 - M5500CVE Mendoza
Tel.: (0261) 438-0528

Rosario
Eva Perón 5357 - S2000BQJ Rosario
Tel.: (0341) 456-2339

Tucumán
Jujuy 779 - T4000IQO Tucumán
Tel.: (0381) 424-2274

FV S.A. se reserva el derecho de introducir mejoras y/o modificaciones de diseño sin previo aviso.

FV S.A. reserve the right to make revisions without notice in the design of faucets and bathroom accesories or in packaging.

FOLLFR217/J2 / AGOSTO 2023